

# Ersatzteilliste

*Spare Parts List / Liste des pièces détachées / Lista di parti di ricambio*

---

## **FSG513P**

*Index / Indice 003*

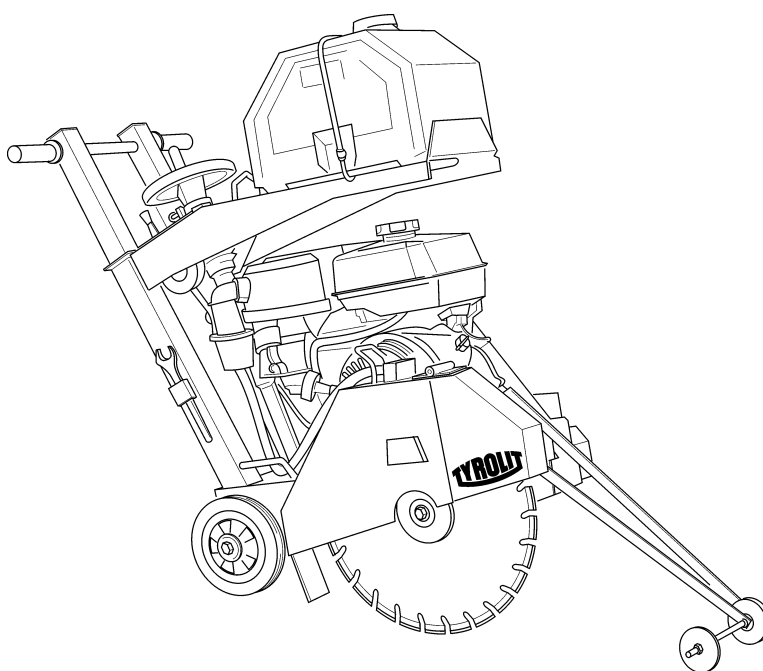

## Verwendung der Ersatzteilliste

Die Ersatzteilliste ist keine Montage- oder Demontageanleitung. Diese Ersatzteilliste dient ausschliesslich zum einfachen und schnellen Finden von Ersatzteilen, die bei der untenstehenden Adresse bestellt werden können.

### Sicherheitsvorschrift



#### Gefahr

**Montieren oder demontieren von Baugruppen kann Risiken bergen, auf die in dieser Ersatzteilliste nicht hingewiesen wird.**

**Das Verwenden dieser Ersatzteilliste für Montage- oder Demontagezwecke ist strikte verboten. Für Montage- und Demontearbeiten sind ausschliesslich die entsprechenden Beschreibungen in der Betriebsanleitung zu befolgen.**

**Nichtbeachten dieser Vorschrift kann zu Verletzungen führen, die im schlimmsten Fall auch den Tod zur Folge haben könnten.**

### Bestellungen



#### Information

Um Falschlieferungen zu vermeiden sollten vor der Versendung die Angaben in der Bestellung auf Richtigkeit und Vollständigkeit (siehe unter Bestellangaben) überprüft werden.

Es ist auch darauf zu achten, dass die Lieferadresse vollständig angegeben ist.

### Bestelladresse:

**TYROLIT Hydrostress AG**  
Witzbergstrasse 18  
CH-8330 Pfäffikon  
Switzerland  
Telefon +41 (0) 44 / 952 18 18  
Telefax +41 (0) 44 / 952 18 18  
e-mail: [info@tyrolit.com](mailto:info@tyrolit.com)  
[www.tyrolit.com](http://www.tyrolit.com)

## 0 Ersatzteilliste

### 0.1 Bestellangaben

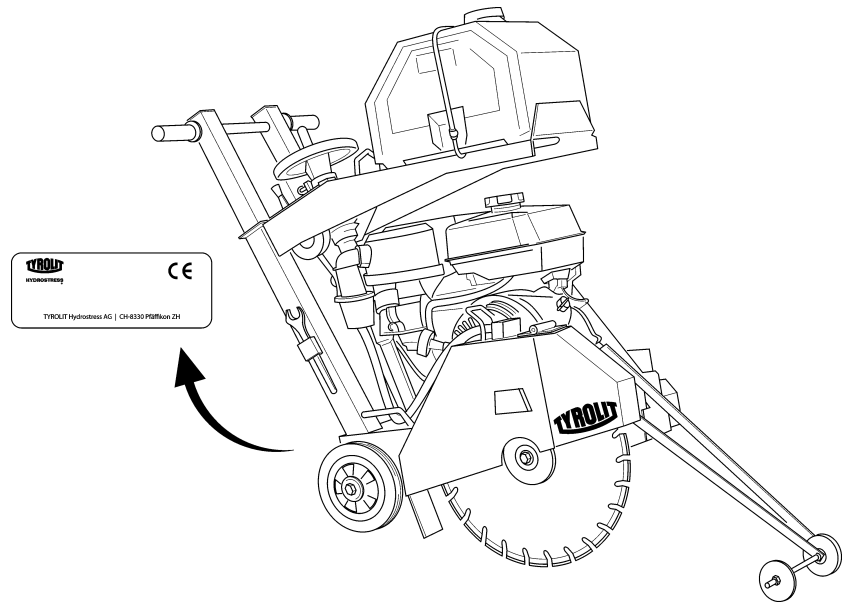

Bei Bestellungen von Ersatzteilen benötigen wir folgende Angaben:

- Maschinentyp gemäss Typenschild
- Maschinennummer gemäss Typenschild
- Maschinenindex gemäss Typenschild
- Ersatzteilnummer gemäss Ersatzteilliste

Für Bestellungen, Fragen und Informationen wenden Sie sich bitte an die zuständige Niederlassung.

## How to use the spare parts list

The spare parts list is not intended as instructions for assembly or dismantling work. It is exclusively intended to help you to quickly and easily find spare parts, which can then be ordered at the address below.

### Safety regulations



#### Danger

**The assembling or dismantling of modules can involve risks which are not identified in this spare parts list.**

**The use of this spare parts list for assembly or dismantling purposes is strictly forbidden. For assembly or dismantling tasks it is essential to only follow the corresponding descriptions in the operating manual.**

**If this regulation is not heeded injuries may be incurred which in the worst case can also be fatal.**

### Ordering



#### Information

To avoid incorrect deliveries you should check the order details for correctness and completeness (see under ordering details) prior shipment.

You should ensure that the delivery address is given in full.

### Order address:

#### **TYROLIT Hydrostress AG**

Witzbergstrasse 18

CH-8330 Pfäffikon

Switzerland

Tel. +41 (0) 44 / 952 18 18

Fax +41 (0) 44 / 952 18 18

e-mail: [info@tyrolit.com](mailto:info@tyrolit.com)

[www.tyrolit.com](http://www.tyrolit.com)

## 0 Spare Parts List

### 0.1 Ordering details

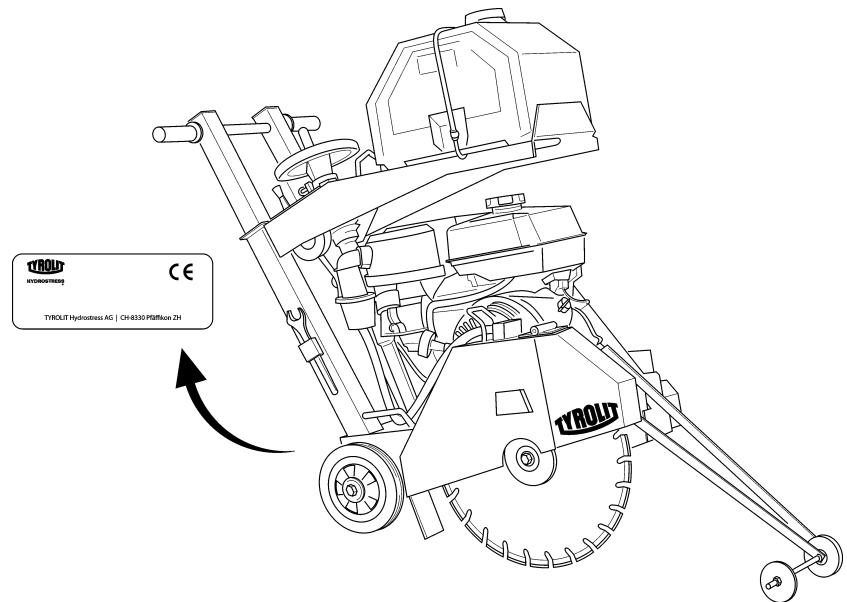

When spare parts are ordered we need the following details:

- Machine type according to nameplate
- Machine number according to nameplate
- Machine index according to nameplate
- Spare part number according to the spare parts list

For orders, questions and information please contact your responsible branch office.

## Utilisation de la liste des pièces détachées

La liste des pièces détachées n'est pas une instruction de montage ou de démontage. Cette liste sert exclusivement à trouver simplement et rapidement les pièces détachées, qui peuvent être commandées à l'adresse mentionnée ci-dessous.

### Prescription de sécurité



#### Danger

**Le montage ou le démontage des modules peut présenter des risques dont il n'est pas fait mention dans cette liste des pièces détachées.**

**Il est strictement interdit d'employer cette liste des pièces détachées à des fins de montage ou de démontage. Pour les opérations de montage et de démontage, il faut exclusivement suivre les descriptions correspondantes dans le mode d'emploi.**

**Le non-respect de la présente prescription peut conduire à des blessures, pouvant même entraîner la mort.**

### Commandes



#### Information

Pour éviter des livraisons inappropriées, il est conseillé de vérifier avant l'expédition l'exactitude et l'exhaustivité des indications fournies dans la commande (voir Données de commande).

Il faut aussi veiller à bien indiquer l'adresse de livraison en entier.

### Adresse de commande :

**TYROLIT Hydrostress AG**

Witzbergstrasse 18

CH-8330 Pfäffikon

Suisse

Téléphone +41 (0) 44 / 952 18 18

Télécopie +41 (0) 44 / 952 18 18

e-mail: [info@tyrolit.com](mailto:info@tyrolit.com)

[www.tyrolit.com](http://www.tyrolit.com)

## 0 Liste des pièces détachées

### 0.1 Données de commande

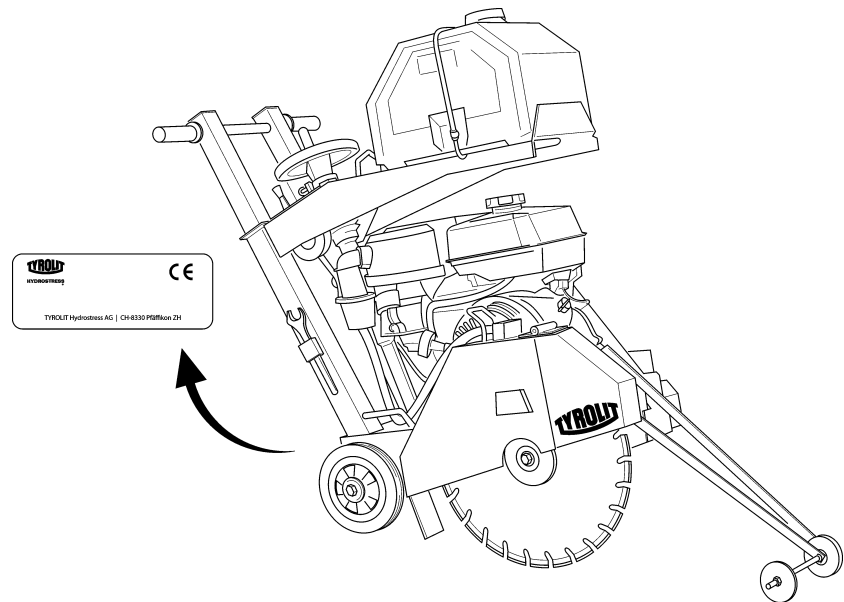

Lors de la commande de pièces détachées, nous avons besoin des données suivantes :

- Type de machine selon la plaque signalétique
- Numéro de machine selon la plaque signalétique
- Indice de machine selon la plaque signalétique
- Numéro de pièce détachée selon la liste des pièces détachées

Pour les commandes, questions et informations, vous êtes prié de vous adresser à la filiale compétente.

## Uso della lista di parti di ricambio

La lista di parti di ricambio non è un manuale d'istruzioni per montaggio o smontaggio. Questa lista di parti di ricambio serve esclusivamente per trovare in modo semplice e rapido parti di ricambio che possono essere ordinate all'indirizzo riportato qui sotto.

### Norme di sicurezza



#### Pericolo

**Il montaggio o lo smontaggio di componenti della macchina può comportare pericoli che non sono indicati in questa lista di parti di ricambio.**

**E' assolutamente vietato servirsi di questa lista di parti di ricambio per scopo di montaggio o di smontaggio. Per operazioni di montaggio o smontaggio occorre seguire esclusivamente le relative istruzioni nel manuale per l'uso della macchina.**

**La mancata osservanza di queste norme può comportare lesioni, e nel caso peggiore anche la morte.**

### Ordinazioni



#### Informazione

Per evitare forniture incorrette, occorre verificare prima dell'invio dell'ordinazione se i dati indicati in essa sono corretti e completi (vedere la lista dei dati per l'ordinazione).

Occorre verificare anche se l'indirizzo per la consegna è esatto e completo.

### Indirizzo per ordinazioni:

**TYROLIT Hydrostress AG**

Witzbergstrasse 18

CH-8330 Pfäffikon

Svizzera

Tel. +41 (0) 44 / 952 18 18

Fax +41 (0) 44 / 952 18 00

e-mail: [info@tyrolit.com](mailto:info@tyrolit.com)

[www.tyrolit.com](http://www.tyrolit.com)



## 0 Lista di parti di ricambio

### 0.1 Dati per l'ordinazione

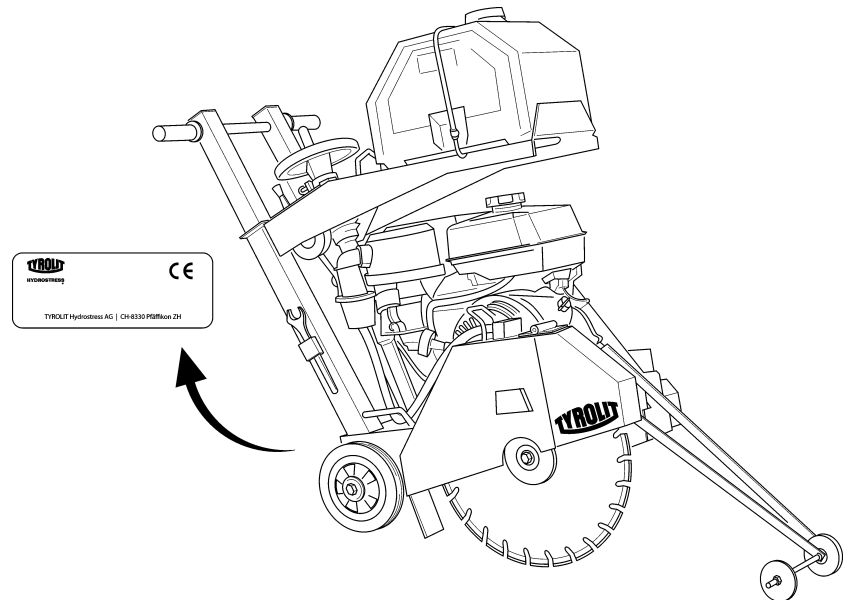

Per ordinazioni di parti di ricambio ci occorrono i dati seguenti:

- Tipo di macchina indicato sulla targhetta della macchina
- Numero della macchina indicato sulla targhetta della macchina
- Indice della macchina indicato sulla targhetta della macchina
- Numero della parte di ricambio secondo la lista di parti di ricambio

Per ordinazioni, domande o richieste d'informazioni Vi preghiamo di rivolgerVi all'agenzia competente.



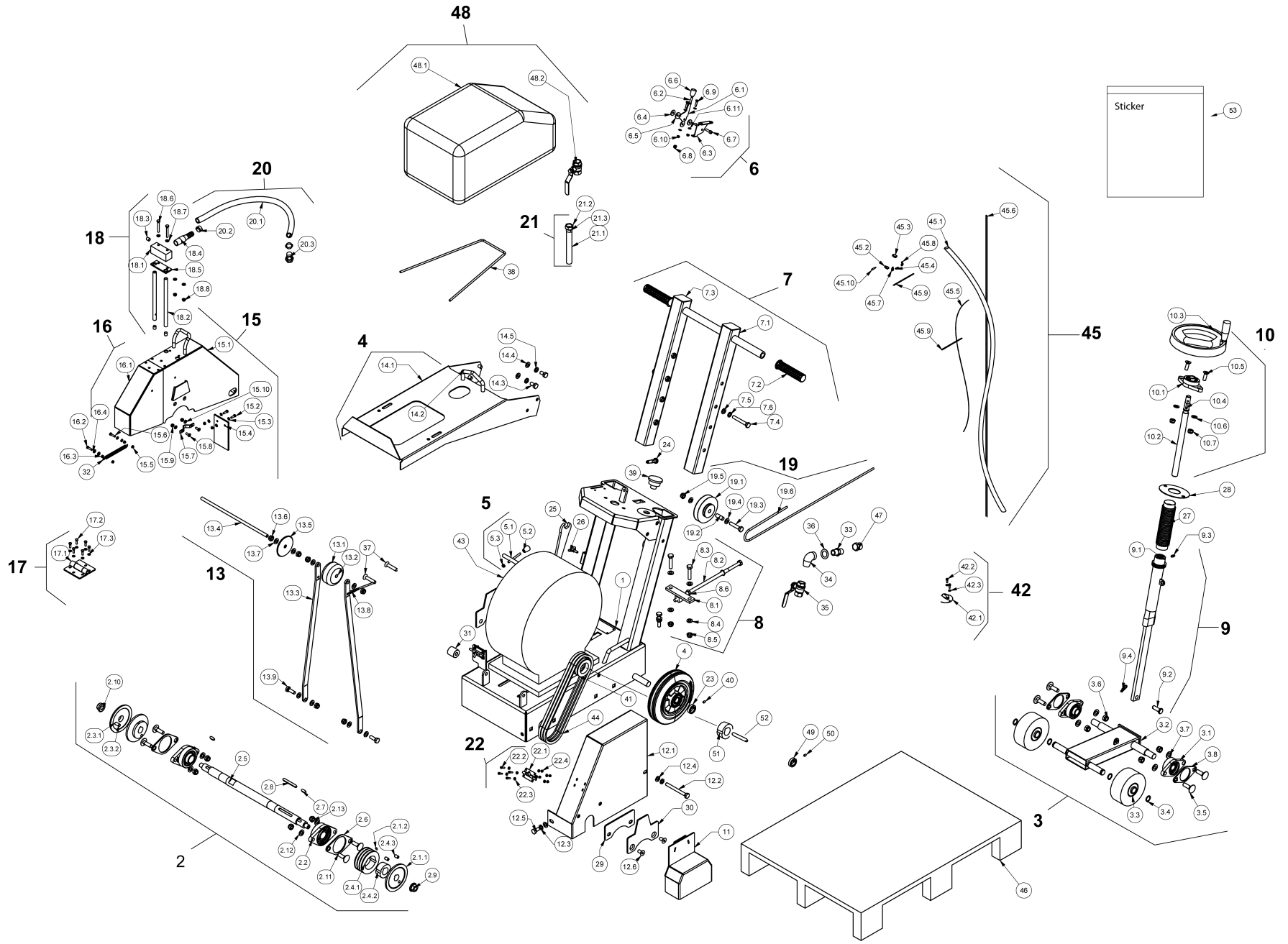

Nr.	Mat. Nr.	Deutsch	English	Français	Italiano	Stk.
1	10989379	Chassis FSG513 EU	Chassis FSG513 EU	Châssis FSG513 EU	Telaio FSG513 EU	1
2	10989356	Antriebswelle kpl.	Drive shaft	Arbre d'entraînement	Albero di comando	1
2.1	10989357	Scheibe kpl.	Washer	Rondelle	Rondella	2
2.1.1	10989380	Scheibe	Washer	Rondelle	Rondella	1
2.1.2	10989306	Gewindestift M5x10	Slotted set screw M5x10	Vis sans tête M5x10	Vite senza testa M5x10	1
2.2	10989327	Flanschlager	Flange bearing	Coussinet de bride	Cuscinetto di flangia	2
2.3	10989358	Feststellscheibe kpl.	Disc	Rondelle	Disco	1
2.3.1	10989381	Feststellscheibe	Disc	Rondelle	Disco	1
2.3.2	10989321	Zylinderstift 10 m6 x 32	Straight pin 10 m6 x 32	Goupille cylindrique 10 m6 x 32	Spina cilindrica 10 m6 x 32	1
2.4	10989359	Keilriemenscheibe kpl.	V-belt washer	Rondelle courroies trapézoïdales	Rondella per cinghie trapezoidali	1
2.4.1	10989353	Keilriemenscheibe	V-belt washer	Rondelle courroies trapézoïdales	Rondella per cinghie trapezoidali	1
2.4.2	10989329	Spannbüchse Taper Lock Ø30	Spring cellet Taper Lock Ø30	Douille de serrage Taper Lock Ø30	Boccola serraglio Taper Lock Ø30	1
2.4.3	10989308	Gewindestift M10x16	Slotted set screw M10x16	Vis sans tête M10x16	Vite senza testa M10x16	2
2.5	10989382	Antriebswelle FSG	Drive shaft FSG	Arbre d'entraînement FSG	Albero di comando FSG	1
2.6	10989328	Distanzhalter	Spacer block	Ecarteur	Distanziatore	2
2.7	10986228	Wellenkeil 8x7x20	Shaft key 8x7x20	Clavette d'arbre 8x7x20	Cuneo dell'albero 8x7x20	2
2.8	10989319	Wellenkeil 8x7x70	Shaft key 8x7x70	Clavette d'arbre 8x7x20	Cuneo dell'albero 8x7x20	1
2.9	10989311	Mutter M16 rechts	Nut M16 right	Ecrou M16 droite	Dado M16 destro	1
2.10	10989383	Mutter M16 links	Nut M16 left	Ecrou M16 gauche	Dado M16 sinistro	1
2.11	10989313	Flachrundschrauben M12x40	Screw M12x40	Vis M12x40	Vite M12x40	4
2.12	971964	U-Scheibe M12 13/24/2,5	U-Washer M12 13/24/2,5	Rondelle U M12 13/24/2,5	Rondella a U M12 13/24/2,5	4
2.13	979309	Stop-Mutter M12 nied.Form	Stop nut M12	Ecrou d'arrêt f.basse M12	Dado d'arresto bas. M12	4
3	10989360	Kippachse	Tipping axis	Axe	Asse	1
3.1	10989325	Flanschlager	Flange bearing	Coussinet de bride	Cuscinetto di flangia	2
3.2	10989384	Heberadkörper	Chassis	Châssis	Telaio	1

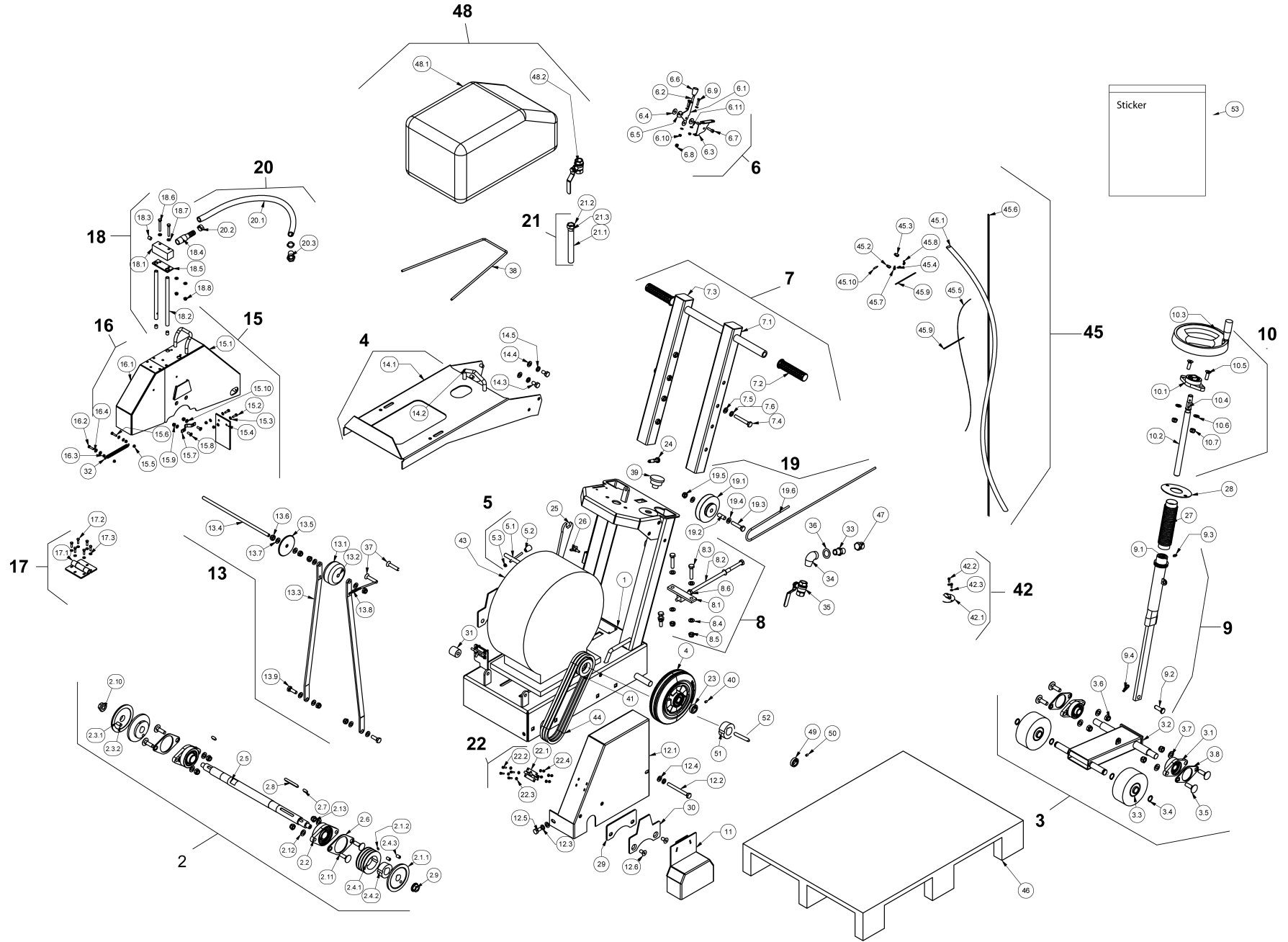

Nr.	Mat. Nr.	Deutsch	English	Français	Italiano	Stk.
3.3	10989334	Heberad Ø125x50	Persian wheel Ø125x50	Roue Ø125x50	Ruota Ø125x50	2
3.4	971994	Seegerring Welle Dm 18	Seeger circlip-ring arbre diam 18	Anneau de retenue Sèggre-arbre diam. 18	Anello tipo seeger albero diam. 18	4
3.5	10989313	Flachrundschrauben M12x40	Screw M12x40	Vis M12x40	Bullone M12x40	4
3.6	979309	Stop-Mutter M12 nied.Form	Stop nut M12	Ecrou d'arrêt f.basse M12	Dado d'arresto bas. M12	4
3.7	971964	U-Scheibe M12 13/24/2,5	U-Washer M12 13/24/2,5	Rondelle U M12 13/24/2,5	Rondella a U M12 13/24/2,5	4
3.8	10989326	Distanzhalter	Spacer block	Ecarteur	Distanziatore	2
4	10989335	Vollgummirad 200/50-100 (WIKE)	Rubbel wheel 200/50-100 (WIKE)	Roue en caoutchouc 200/50-100 (WIKE)	Ruota in gomma 200/50-100 (WIKE)	2
5	10989361	Bremshebel kpl.	Brake lever	Levier de frein	Leva del freno	1
5.1	10989385	Bremshebel	Brake lever	Levier de frein	Leva del freno	1
5.2	973619	Griff	Handle	Poignée	Manopola	1
5.3	979308	Stop-Mutter M6 nied.Form	Stop nut M6	Ecrou d'arrêt f.basse M6	Dado d'arresto bas. M6	1
6	10989362	Gashebel kpl.	Accelerator lever	Levier de gas	Leva del gas	1
6.1	10989386	Gashebel-1	Accelerator lever -1	Levier de gas -1	Leva del gas -1	1
6.2	10989316	Einpress-Gewindebolzen M6x25	Stud bolt M6x25	Guion fileté M6x25	Bullonge filettato M6x25	1
6.3	10989387	Gashebel Grundplatte	Accelerator lever base plate	Levier de gas plaque de base	Leva del gas piastra di base	1
6.4	979351	U-Scheibe Dm 6.4x18.5x1.6	U-Washer diam 6.4x18.5x1.6	Rondelle U diam 6.4x18.5x1.6	Rondella a U diam 6.4x18.5x1.6	3
6.5	10989388	Gashebel-2	Accelerator lever -2	Levier de gas -2	Leva del gas -2	1
6.6	973619	Griff	Handle	Poignée	Manopola	1
6.7	971709	Inbus-Schraube M6x20	Allen head screw M6x20	Vis à six pans creux M6x20	Vite ad esagono cavo M6x20	1
6.8	979308	Stop-Mutter M6 nied.Form	Stop nut M6	Ecrou d'arrêt f.basse M6	Dado d'arresto bas. M6	1
6.9	10989315	6kt-Schraube M5x20	Hexagonal screw M5x20	Vis à tête hexagonale M5x20	Vite a testa esagonale M5x20	2
6.10	971859	Stop-Mutter M5 nied.Form	Stop nut M5	Ecrou d'arrêt f.basse M5	Dado d'arresto bas. M5	2
6.11	971953	U-Scheibe M5 5,3/9/1	U-Washer M5 13/24/2,5	Rondelle U M5 13/24/2,5	Rondella a U M5 13/24/2,5	4
7	10989363	Lenker kpl.	Connecting rod	Guidon	Sterzo	1
7.1	10989389	Lenkerholmen	Steering linkage idler arm	Guidon	Manubrio	1
7.2	973618	Gummigriff	Handle	Poignée	Manopola	2
7.3	10989320	Rechteckstopfen 50/50	Plug	Bouchon	Tappo	2
7.4	984993	6kt-Schraube M10x70	Hexagonal screw M10x70	Vis à tête hexagonale M10x70	Vite a testa esagonale M10x70	2
7.5	971963	U-Scheibe M10 10,5/20/2	U-Washer M10 10,5/20/2	Rondelle U M10 10,5/20/2	Rondella a U M10 10,5/20/2	2
7.6	971631	Federring M10 DIN 127 A	Spring washer M10 DIN 127 A	Rondelle élastique bombée M10 DIN 127 A	Rosetta elastica M10 DIN 127 A	2

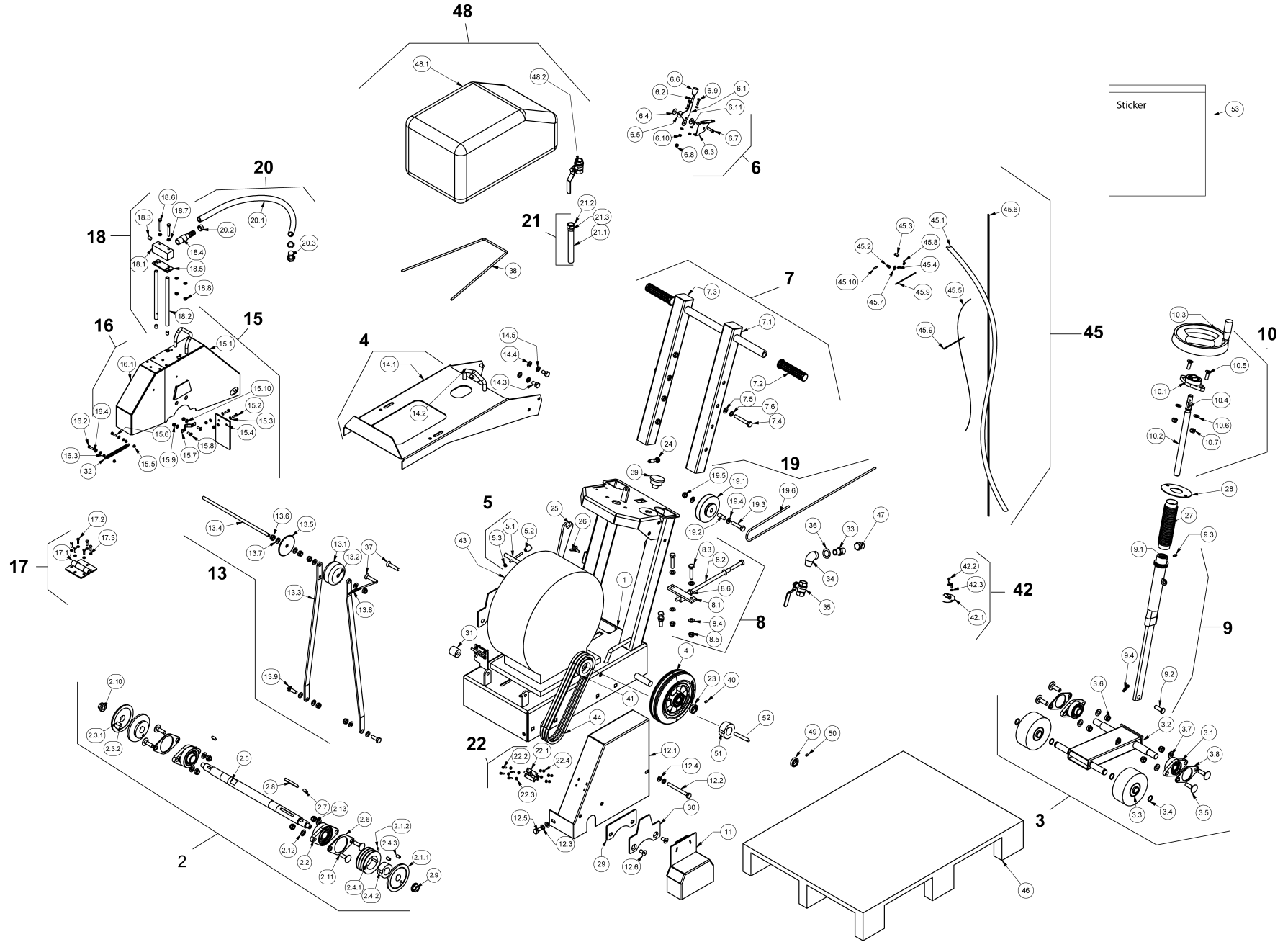

№	Nr.	Mat. Nr.	Deutsch	English	Français	Italiano	Stk.
	8	10989364	Motorspanner kpl.	Tension jack	Tenseur	Tenditore	1
	8.1	10989390	Motorspannerplatte	Tension jack plate	Plaque tenseur	Piastra tenditrice	1
	8.2	10989391	Geschw. Gewindestange	All-thread hanger rod	Tige filetée	Barra filettata	1
	8.3	971909	6kt-Schraube M10x50	Hexagonal screw M10x50	Vis à tête hexagonale M10x50	Vite a testa esagonale M10x50	4
	8.4	971963	U-Scheibe M10 10,5/20/2	U-Washer M10 10,5/20/2	Rondelle U M10 10,5/20/2	Rondella a U M10 10,5/20/2	6
	8.5	971862	Stop-Mutter M10 nied.Form	Stop nut M10	Ecrou d'arrêt f.basse M10	Dado d'arresto bas. M10	4
	8.6	971848	Mutter M10	Nut M10	Ecrou M10	Dado M10	1
	9	10989365	Höhenverstellung kpl.	Adjustabler	Régulateur en hauteur	Regolatore di altezza	1
	9.1	10989392	Verstellachse	Shaft	Axe	Albero	1
	9.2	10989318	Splintbolzen Ø12x35	Cotter bolt Ø12x35	Goujon Ø12x35	Bullone Ø12x35	1
	9.3	10989336	Schmiernippel H1 M6	Grease nipple H1 M6	Fileté de graissage H1 M6	Ingrassatore H1 M6	1
	9.4	10979423	Vorsteckfeder Dm 3,0 x 60	Spring	Ressort	Molla	1
	10	10989366	Handrad kpl.	Handwheel	Roue à main	Manovella	1
	10.1	10989324	Flanschlager	Flange bearing	Coussinet de bride	Cuscinetto di flangia	1
	10.2	10989393	Spindel	Bolt	Broche	Asta filettata	1
	10.3	10989331	Handrad Ø200/Ø30	Handwheel Ø200/Ø30	Roue à main Ø200/Ø30	Manovella Ø200/Ø30	1
	10.4	10989322	Schwer-Spannstift 6x35	Rollpin 6x35	Goupille fendue 6x35	Perno tenditore 6x35	1
	10.5	10989309	Senkkopfschraube M10x 30	Countersunk head screw M10x30	Vis à tête fraisée M10x30	Vite a testa svasata M10x30	2
	10.6	971963	U-Scheibe M10 10,5/20/2	U-Washer M10 10,5/20/2	Rondelle U M10 10,5/20/2	Rondella a U M10 10,5/20/2	2
	10.7	971862	Stop-Mutter M10 nied.Form	Stop nut M10	Ecrou d'arrêt f.basse M10	Dado d'arresto bas. M10	2
	10.8	10992137	Zylinderstift 5m6x20	Straight pin 5m6x20	Goupille cylindrique 5m6x20	Spina cilindrica 5m6x20	1
	11	10989394	Schutzabdeckung	Protection	Protection	Protezione	1
	12	10989367	Keilriemenhaube kpl.	V-belt cowling	Capot courroies trapézoïdales	Calotta per cinghie trapezoidali	1
	12.1	10989395	Keilriemenhaube	V-belt cowling	Capot courroies trapézoïdales	Calotta per cinghie trapezoidali	1
	12.2	10987116	6kt-Schraube M10x100	Hexagonal screw M10x100	Vis à tête hexagonale M10x100	Vite a testa esagonale M10x100	1
	12.3	971631	Federring M10 DIN 127 A	Spring washer M10 DIN 127 A	Rondelle élastique bombée M10 DIN 127 A	Rosetta elastica M10 DIN 127 A	2
	12.4	971963	U-Scheibe M10 10,5/20/2	U-Washer M10 10,5/20/2	Rondelle U M10 10,5/20/2	Rondella a U M10 10,5/20/2	2
	12.5	984994	6kt-Schraube M10x20	Hexagonal screw M10x20	Vis à tête hexagonale M10x20	Vite a testa esagonale M10x20	1
	12.6	984996	Senkkopfschraube M10x 20	Countersunk head screw M10x20	Vis à tête fraisée M10x20	Vite a testa svasata M10x20	2



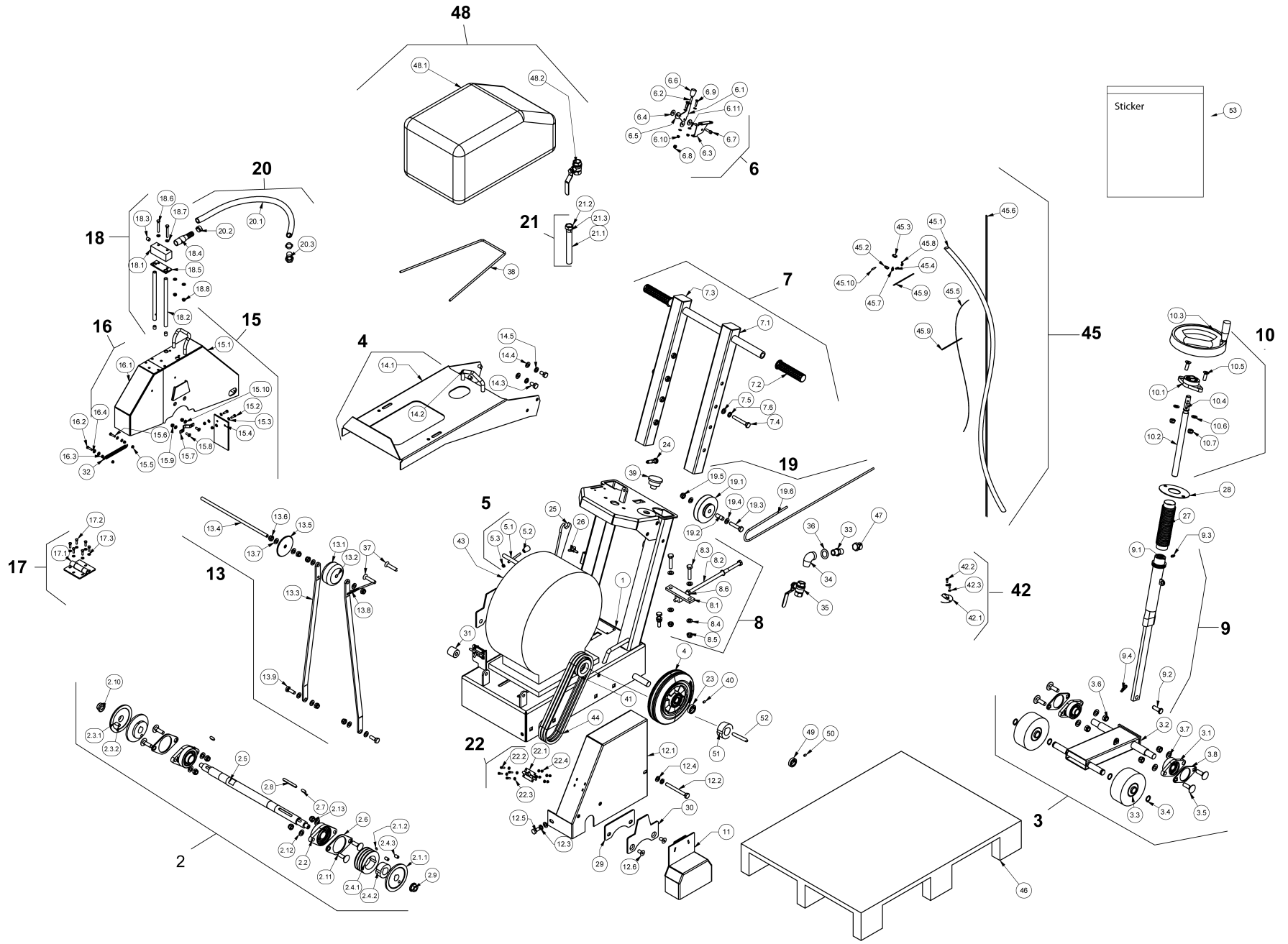

№	Nr.	Mat. Nr.	Deutsch	English	Français	Italiano	Stk.
	13	10989368	Führungsrad kpl.	Guide wheel	Roue de guidance	Ruota guidatrice	1
	13.1	10989333	Führungsrad Ø80/35	Guide wheel Ø80/35	Roue de guidance Ø80/35	Ruota guidatrice Ø80/35	1
	13.2	10989396	Führungsradbüchse	Bearing box guide wheel	Douille de roue de guidance	Boccola ruota guidatrice	1
	13.3	10989397	Führungsstange	Guide bar	Barre de guidage	Asta di guida	2
	13.4	10989398	M-10 Gewindestange	All-thread hanger rod M-10	Tige filetée M-10	Barra filettata M-10	1
	13.5	10989399	Rad	Wheel	Roue	Ruota	1
	13.6	971862	Stop-Mutter M10 nied.Form	Stop nut M10	Ecrou d'arrêt f.basse M10	Dado d'arresto bas. M10	6
	13.7	971963	U-Scheibe M10 10,5/20/2	U-Washer M10 10,5/20/2	Rondelle U M10 10,5/20/2	Rondella a U M10 10,5/20/2	8
	13.8	10981069	Poliesterseil Ø8	Wire polyester Ø8	Corde en polyester Ø8	Corda in poliestere Ø8	1850mm
	13.9	971907	6kt-Schraube M10x30	Hexagonal screw M10x30	Vis à tête hexagonale M10x30	Vite a testa esagonale M10x30	2
	14	10989369	Wasserbehälterauflage kpl.	Chassis	Châssis	Telaio	1
	14.1	10989401	Auflageblech	Cloth plate	Surface en tôle	Banda d'appoggio	1
	14.2	10989402	Griff	Handle	Poignée	Manopola	1
	14.3	984994	6kt-Schraube M10x20	Hexagonal screw M10x20	Vis à tête hexagonale M10x20	Vite a testa esagonale M10x20	4
	14.4	971963	U-Scheibe M10 10,5/20/2	U-Washer M10 10,5/20/2	Rondelle U M10 10,5/20/2	Rondella a U M10 10,5/20/2	4
	14.5	971631	Federring M10 DIN 127 A	Spring washer M10 DIN 127 A	Rondelle élastique bombée M10 DIN 127 A	Rosetta elastica M10 DIN 127 A	4
	15	10989370	Blattschutz kpl.	Blade guard	Protection du disque	Protezione del disco	1
	15.1	10989403	Blattschutz	Blade guard	Protection du disque	Protezione del disco	1
	15.2	10989314	6kt-Schraube M5x16	Hexagonal screw M5x16	Vis à tête hexagonale M5x16	Vite a testa esagonale M5x16	2
	15.3	971953	U-Scheibe M5 5,3/9/1	U-Washer M5 5,3/9/1	Rondelle U M5 5,3/9/1	Rondella a U M5 5,3/9/1	6
	15.4	10989404	Schutzgummi	Rubber protection	Protection en gomme	Protezione in gomma	1
	15.5	971859	Stop-Mutter M5 nied.Form	Stop nut M5	Ecrou d'arrêt f.basse M5	Dado d'arresto bas. M5	4
	15.6	10989315	6kt-Schraube M5x20	Hexagonal screw M5x20	Vis à tête hexagonale M5x20	Vite a testa esagonale M5x20	1
	15.7	10989405	Rohrbefestigung	Piping anchorage	Fixation de tuyau	Fissaggio del tubo	2
	15.8	971822	Senkkopfschraube M6x 16	Countersunk head screw M6x16	Vis à tête fraisée M6x16	Vite a testa svasata M6x16	4
	15.9	979308	Stop-Mutter M6 nied.Form	Stop nut M6	Ecrou d'arrêt f.basse M6	Dado d'arresto bas. M6	4
	15.10	971955	U-Scheibe M6 6,4/11/1,6	U-Washer M6 6,4/11/1,6	Rondelle U M6 6,4/11/1,6	Rondella a U M6 6,4/11/1,6	4
	16	10989194	Blattschutz Kippteil kpl. 18"	Blade guard 18"	Protection du disque 18"	Protezione del disco 18"	1
		10989195	Blattschutz Kippteil kpl. 14"	Blade guard 14"	Protection du disque 14"	Protezione del disco 14"	
	16.1	10989406	Blattschutz 2 – Kippteil 18"	Blade guard 2 - 18"	Protection du disque 2 - 18"	Protezione del disco 2 - 18"	1
		10989407	Blattschutz 2 – Kippteil 14"	Blade guard 2 - 14"	Protection du disque 2 - 14"	Protezione del disco 2 - 14"	

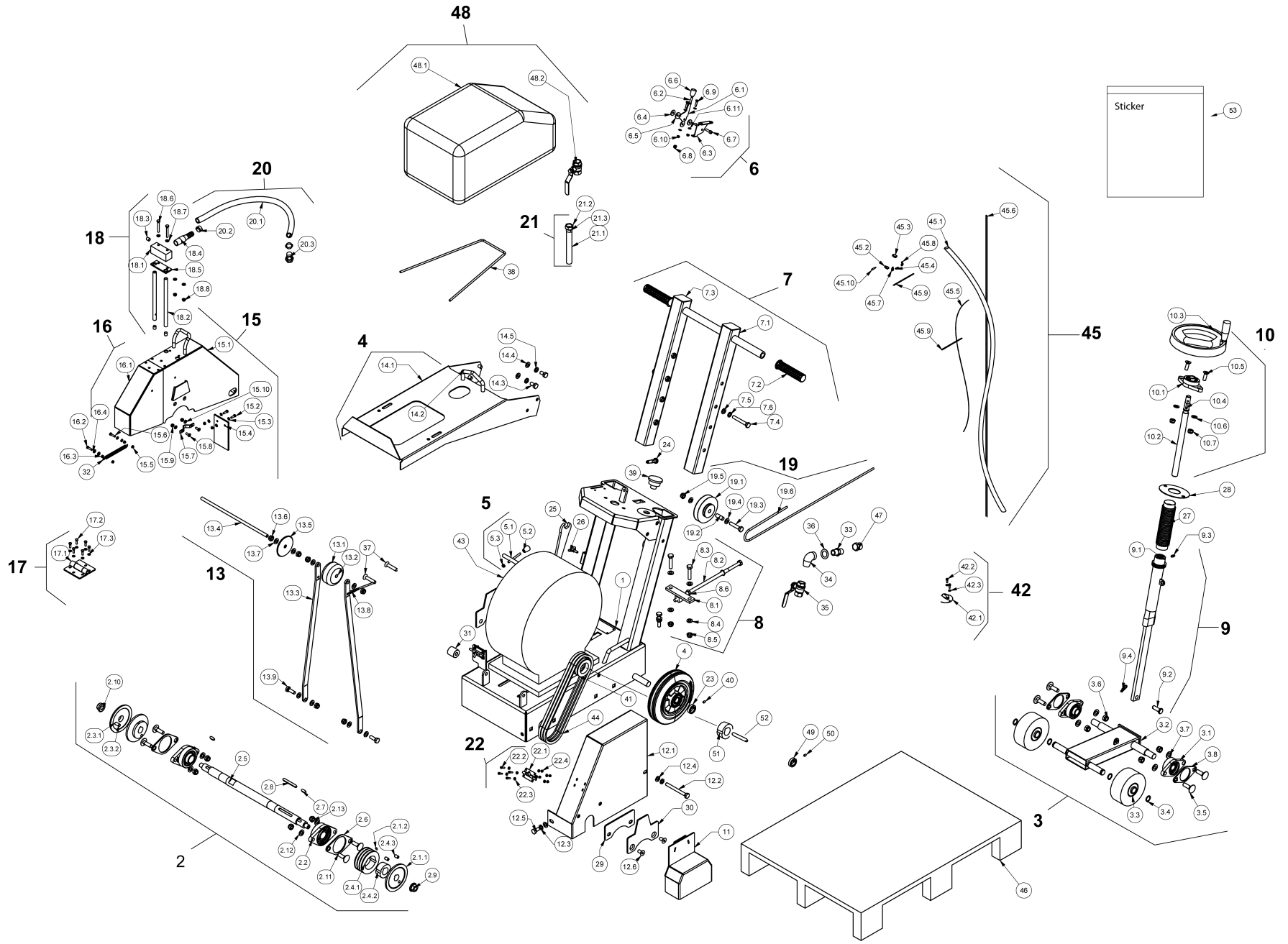

Nr.	Mat. Nr.	Deutsch	English	Français	Italiano	Stk.
16.2	10989315	6kt-Schraube M5x20	Hexagonal screw M5x20	Vis à tête hexagonale M5x20	Vite a testa esagonale M5x20	1
16.3	971859	Stop-Mutter M5 nied.Form	Stop nut M5	Ecrou d'arrêt f.basse M5	Dado d'arresto bas. M5	2
16.4	971955	U-Scheibe M6 6,4/11/1,6	U-Washer M6 6,4/11/1,6	Rondelle U M6 6,4/11/1,6	Rondella a U M6 6,4/11/1,6	2
17	10989408	Blattschutzscharnier kpl.	Blade guard articulation	Charnière protection du disque	Cerniera protezione disco	1
17.1	10989330	Blattschutzscharnier	Blade guard articulation	Charnière protection du disque	Cerniera protezione disco	1
17.2	10989314	6kt-Schraube M5x16	Hexagonal screw M5x16	Vis à tête hexagonale M5x16	Vite a testa esagonale M5x16	6
17.3	971953	U-Scheibe M5 5,3/9/1	U-Washer M5 5,3/9/1	Rondelle U M5 5,3/9/1	Rondella a U M5 5,3/9/1	12
18	10989371	Blattkühlung kpl.	Blade cooling	Refroidissement du disque	Raffreddamento disco	1
18.1	10989409	Kühlerblock	Radiator block	Radiateur	Radiatore	1
18.2	10989410	Kühlerrohr	Radiator tube	Tuyau de radiateur	Tube del radiatore	2
18.3	971638	Gewindestift M10x12	Slotted set screw M10x12	Vis sans tête M10x12	Vite senza testa M10x12	3
18.4	10989348	Schlauchtülle 1/2"	Hose clip 1/2"	Douille 1/2"	Manichetta 1/2"	1
18.5	10989411	Isoliergummi	Insulating rubber	Gomme isolante	Gomma isolante	1
18.6	971894	6kt-Schraube M6x45	Hexagonal screw M6x45	Vis à tête hexagonale M6x45	Vite a testa esagonale M6x45	2
18.7	971955	U-Scheibe M6 6,4/11/1,6	U-Washer M6 6,4/11/1,6	Rondelle U M6 6,4/11/1,6	Rondella a U M6 6,4/11/1,6	4
18.8	979308	Stop-Mutter M6 nied.Form	Stop nut M6	Ecrou d'arrêt f.basse M6	Dado d'arresto bas. M6	2
19	10989372	Schnitttiefeanzeige	Deepness display	Indication de gravité	Indicatore di profondità	1
19.1	10989412	Skalenrad	Graduation	Graduation	Graduazione	1
19.2	10989413	Büchse	Bush	Douille	Boccola	1
19.3	971909	6kt-Schraube M10x50	Hexagonal screw M10x50	Vis à tête hexagonale M10x50	Vite a testa esagonale M10x50	1
19.4	971963	U-Scheibe M10 10,5/20/2	U-Washer M10 10,5/20/2	Rondelle U M10 10,5/20/2	Rondella a U M10 10,5/20/2	2
19.5	971862	Stop-Mutter M10 nied.Form	Stop nut M10	Ecrou d'arrêt f.basse M10	Dado d'arresto bas. M10	1
19.6	975960	Gummizug 600mm	Elastic band 600mm	Elastique 600mm	Elastico 600mm	1
20	10989373	Wasserschlauch kpl.	Water hose	Tuyau	Tube	1
20.1	961808	Wasserschlauch l=860mm	Water hose l=860mm	Tuyau l=860mm	Tube l=860mm	860mm
20.2	980228	Schlauchbride	Hose clip	Bride de tuyau	Brida di tubi	2
20.3	10989349	Innengewindetülle 1/2"	Threaded nozzle 1/2"	Douille fileté 1/2"	Becco filettato 1/2"	1
21	10989374	Tankanschluss kpl.	Connection	Raccordement	Raccordo	1
21.1	961808	Wasserschlauch l=150mm	Water hose l=150mm	Tuyau l=150mm	Tube l=150mm	150mm
21.2	10989349	Innengewindetülle 1/2"	Threaded nozzle 1/2"	Douille fileté 1/2"	Becco filettato 1/2"	1
21.3	980228	Schlauchbride	Hose clip	Bride de tuyau	Brida di tubi	1

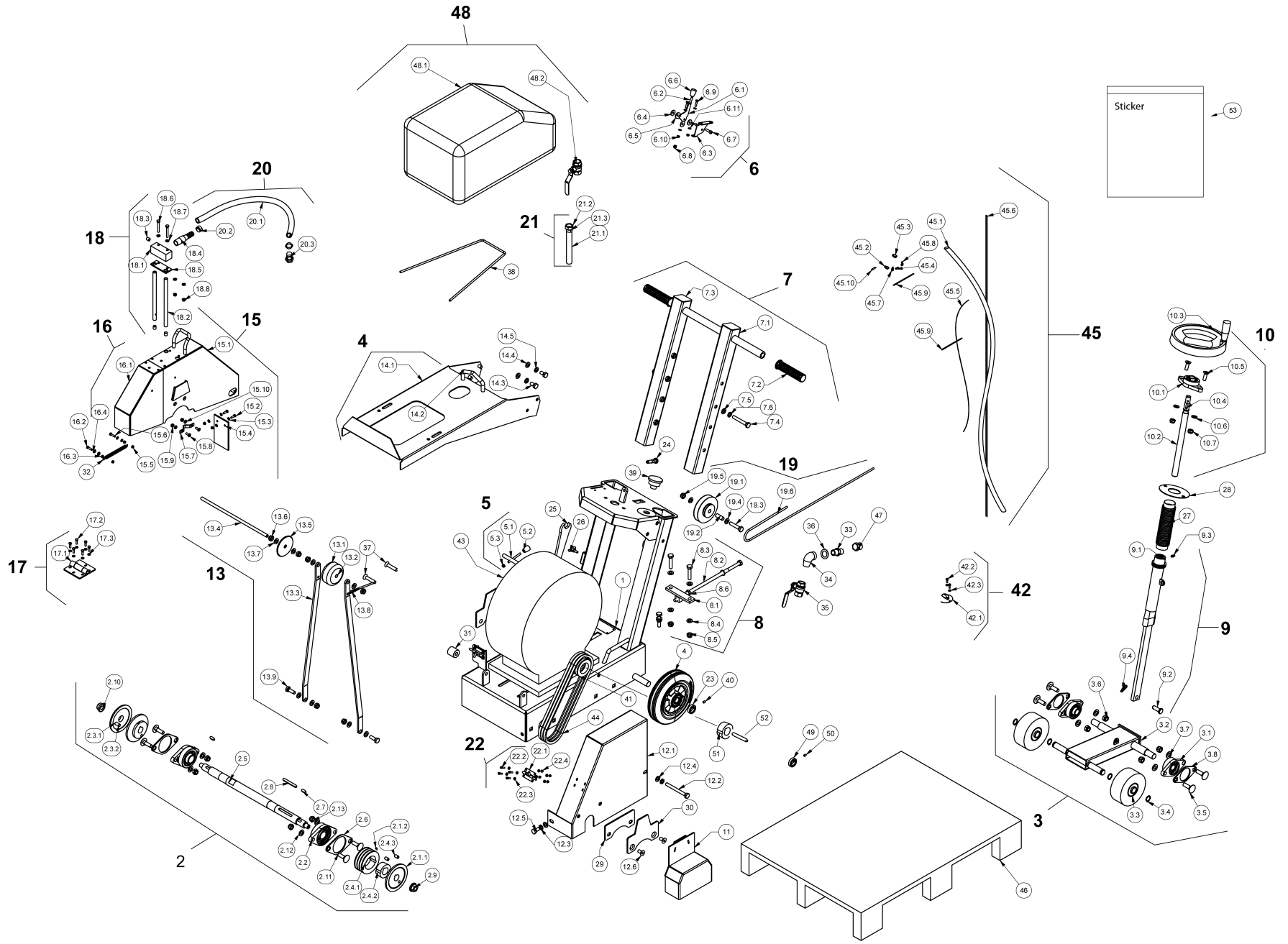

Nr.	Mat. Nr.	Deutsch	English	Français	Italiano	Stk.
22	10989375	Riegel 65 mm kpl.	Catch 65 mm	Verrou 65 mm	Barra 65 mm	2
23	10989317	Stelling Ø20/32/M6	Adjusting collar Ø20/32/M6	Anneau regulateur Ø20/32/M6	Anello regolatore Ø20/32/M6	2
24	979585	Rastbolzen M10x1 Dm 6	Locking bolt M10x1 Dm 6	Boulon d'arret M10x1 Dm 6	Perno blocco carrello M10x1 Dm 6	1
22.1	10989350	Riegel 50x33/Ø7	Catch 50x33/Ø7	Verrou 50x33/Ø7	Barra 50x33/Ø7	1
22.2	971680	Inbus-Schraube M4x16	Allen head screw M4x16	Vis à six pans creux M4x16	Vite ad esagono cavo M4x16	4
22.3	971952	U-Scheibe M4 4,3/8/0,5	U-Washer M4 4,3/8/0,5	Rondelle U M4 4,3/8/0,5	Rondella a U M4 4,3/8/0,5	8
22.4	971858	Stop-Mutter M4 nied.Form	Stop nut M4	Ecrou d'arrêt f.basse M4	Dado d'arresto bas. M4	4
25	973773	Gabelschlüssel	Flat wrench	Clè a fourche	Chiave	1
26	10989312	Flügel Schr. M6x16	Screw M6x16	Vis M6x16	Vite M6x16	1
27	10989351	Faltenbalg Ø70/140	Boot Ø70/140	Soufflet Ø70/140	Manicotto di tenuta a soffietto Ø70/140	1
28	10989414	Faltenbalgbefestigung	Boot anchorage	Fixation soufflet	Fissaggio manicotto a soffietto	1
29	10989415	Distanzhalter-1	Spacer block-1	Ecarteur-1	Distanziatore-1	1
30	10989416	Einhängeblech	Plate	Tôle	Lamiera	2
31	10989417	D30-Distanzhalter	D30-Spacer block	D30-Ecarteur	D30-Distanziatore	2
32	10989323	Zugfeder Ø10x85	Extension spring Ø10x85	Ressort de traction Ø10x85	Molla di trazione Ø10x85	1
33	10989338	Ger.Verschr. 1/2-18L	Straight screw connection 1/2-18L	Vissage droit 1/2-18L	Avvitamento diritto 1/2-18L	1
34	973706	Winkel GF92 1/2 A-1/2 I	Right-angle GF92 1/2 A-1/2 I	Jarret GF92 1/2 A-1/2 I	Angolo GF92 1/2 A-1/2 I	1
35	10989337	Kugelhahn 1/2"	Ball valve 1/2"	Robinet d'eau à bille 1/2"	Rubinetto sferico 1/2"	1
36	972188	Kupferdichtung G 1/2	Copper gasket G1/2"	Joint en cuivre G1/2"	Guarnizione in rame G1/2"	1
37	10989310	Senkkopfschraube M10x 50	Countersunk head screw M10x50	Vis à tête fraisée M10x50	Vite a testa svasata M10x50	2
38	975960	Gummizug 600mm	Elastic band 600mm	Elastique 600mm	Elastico 600mm	1
39	10994935	Notausschalter FSG513	Emergency stop switch FSG513	Coffret d'arret d'urgence vide FSG513	Bottone di emergenza FSG513	1
40	10989307	Gewindestift M 6x8	Slotted set screw M6x8	Vis sans tête M6x8	Vite senza testa M6x8	2
41	10989352	Keilriemenscheibe	V-belt washer	Rondelle courroies trapézoïdales	Rondella per cinghie trapezoidali	1
42	10989376	Auspuff kpl.	Exhaus emission	Echappement	Scarico	1
42.1	10985248	Auspuff	Exhaus emission	Echappement	Scarico	1
42.2	971679	Inbus-Schraube M4x12	Allen head screw M4x12	Vis à six pans creux M4x12	Vite ad esagono cavo M4x12	3
42.3	971952	U-Scheibe M4	U-Washer M4	Rondelle U M4	Rondella a U M4	3
43	10989332	Honda-Motor GX 390 / 389ccm	Motor Honda GX390/389ccm	Moteur Honda GX390 / 389ccm	Motore Honda GX390 / 389 ccm	1
44	10994950	Keilriemen-Set Optibelt (3St.)	V-belt Optibelt (3x)	Courroies trapézoïdales Optibelt (3x)	Cinghia trapezoidale Optibelt (3x)	3

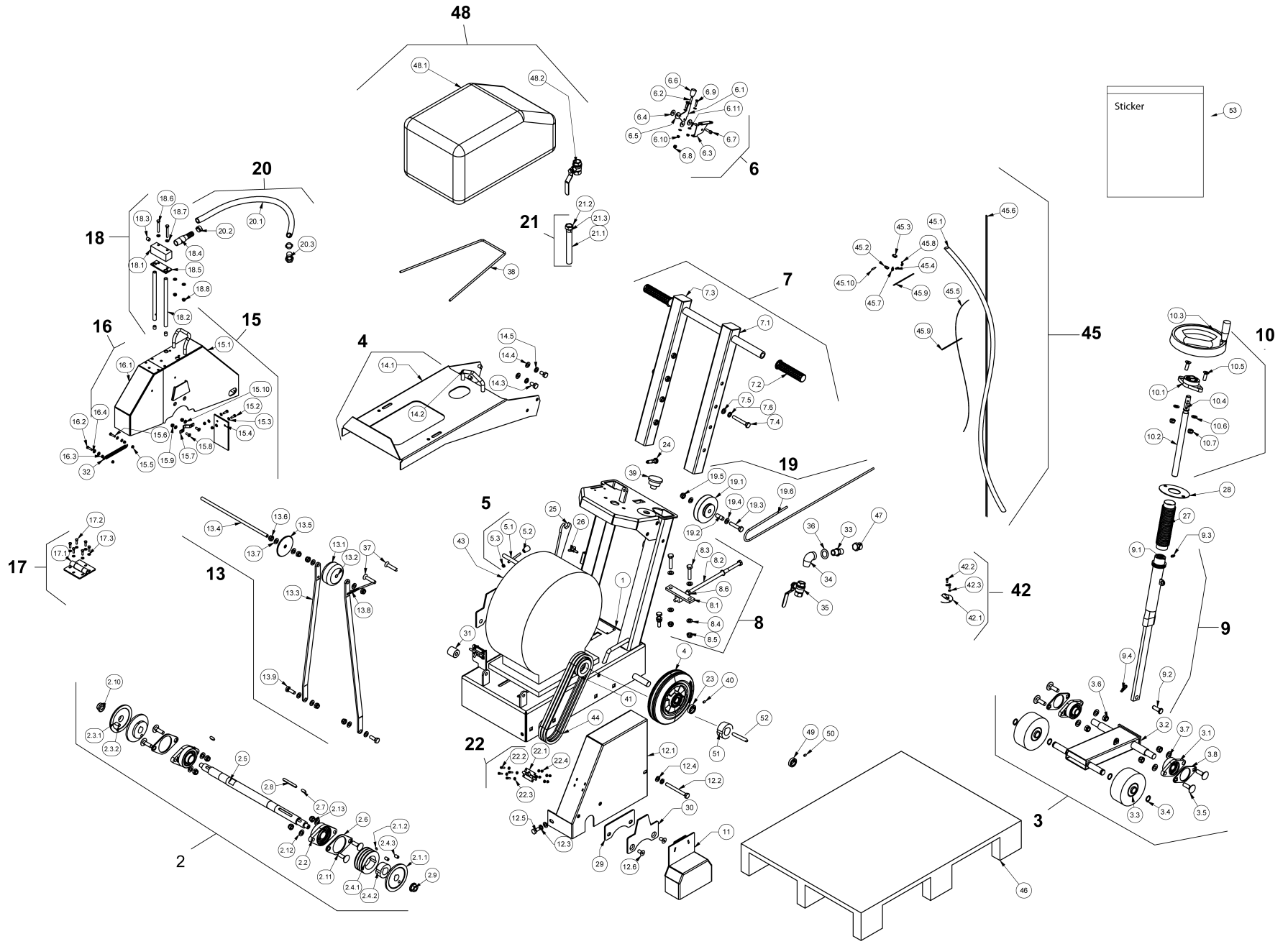

Nr.	Mat. Nr.	Deutsch	English	Français	Italiano	Stk.
45	10989377	Verkabelung kpl.	Cabling	Câblage	Cablaggio	1
45.1	10989340	Schutzschlauch	Hose protection	Protection de tuyau	Protezione tubo	1
45.2	10989341	Überzug Kabelschuh Kupplung	Cover	Gaine	Involucro	1
45.3	10989342	Überzug Kabelschuh Stecker	Cover	Gaine	Involucro	1
45.4	10989343	Stecker	Plug	Prise	Spina	1
45.5	10989344	Kabel schwarz	Cable	Câble	Cavo	1
45.6	10989345	Kabel 2-adrig	Cable	Câble	Cavo	1
45.7	10989346	Kupplung	Coupling	Raccord	Giunto	1
45.8	10989347	Kabelschuh	Cable element	Élément pour cable	Elemento per cavi	1
45.9	980225	Kabelbinder TY24MX140x3,6	Cable clip TY24MX140x3,6	Pince câble TY24MX140x3,6	Legacavo TY24MX140x3,6	2
46	974015	1/2 Einwegpalett 60x80cm	1/2 Pallett 60x80cm	1/2 palet 60x80cm	1/2 Bancale 60x80cm	1
47	966422	Fitting Vaterstück	Fitting	Fitting	Fitting	1
48	10989378	Wassertank 25l kpl.	Water tank 25l	Citerne 25l	Cisterna 25l	1
48.1	10989355	Wassertank 25L 380x300x300	Water tank 25l 380x300x300	Citerne 25l 380x300x300	Cisterna 25l 380x300x300	1
48.2	984713	Wasserhahn Plastic-Tank	Water tap	Robinet d'eau	Rubinetto	1
49	10989430	Stelling	Adjusting collar	Anneau regulateur	Anello regolatore	1
50	10989432	Gewindestift M6x12	Slotted set screw M6x12	Vis sans tête M6x12	Vite senza testa M6x12	1
51	10989462	Spannbüchse Taper Lock	Spring cellet Taper Lock	Douille de serrage Taper Lock	Boccola serraglio Taper Lock	1
52	10989433	Wellenkeil	Shaft key	Clavette d'arbre	Cuneo dell'albero	1
53	10996541	Stickerset	Stickers	Stickers	Stickers	1