

Operating Manual

Spare Parts List

Flat Saw

HFS811

Index / Indice «000»

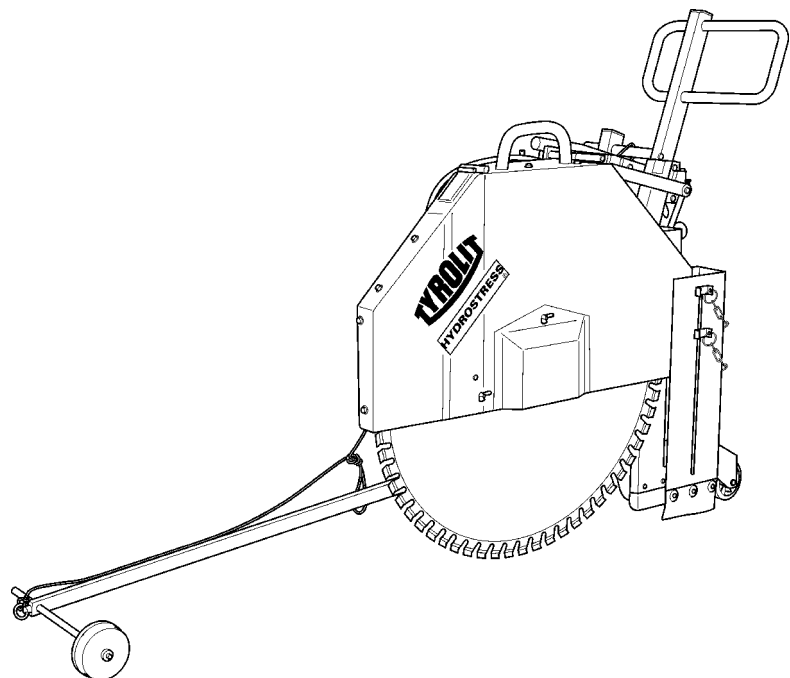

Manufacturer's address:

TYROLIT Hydrostress AG

Witzbergstrasse 18

CH-8330 Pfäffikon

Switzerland

Tel. +41 (0)44 952 18 18

Fax +41 (0)44 952 18 00

www.tyrolit.com

TYROLIT Hydrostress AG reserves the right to make technical changes without prior notice.

Copyright © 2005 TYROLIT Hydrostress AG, CH-8330 Pfäffikon ZH, Switzerland

All rights reserved, in particular copyrighting and translating rights.

Printing of this operating manual, including extracts from it, is prohibited. No parts of it may be reproduced in any form or processed using electronic systems, duplicated or disseminated without the written permission of TYROLIT Hydrostress AG.

Preface to the operating manual

This operating manual makes it easier to become familiar with the machine and to use it properly.

The operating manual contains important information on how to operate the machine safely, properly and efficiently. Following the operating manual helps avoid danger, reduce repair costs and downtime, and increase the machine's reliability and life.

The operating manual must be supplemented with instructions based on national regulations for accident prevention and environmental protection.

The operating manual must always be readily available at the location where the machine is used.

The operating manual must be read and used by any person assigned tasks with the machine, such as:

- **operation**, including set-up, repair of malfunctions during operation, disposal of production waste, maintenance, disposal of materials
- **maintenance** (service, inspection, or repair) and/or
- **Transport**

In addition to the operating manual and the regulations for accident prevention in force in the country and at the location where the machine is used, recognised technical rules for safe and correct operation must be followed.

Table of contents

1. Basic safety instructions
2. Machine description
3. Placement in operation
4. Transport
5. Operation
6. Shut-down
7. Maintenance
8. Repair of malfunctions
10. Warranty

1. Basic safety instructions

1.1 Warnings and symbols in this manual

Danger! Points out that serious or even fatal injuries may result if not followed.

Caution! Points out that injuries may result if not followed.

Note

 Points out that damage to the machine or other equipment may result if not followed.

1.2 Principle of intended use

1.2.1 The machine has been constructed using the latest technology and in accordance with recognised safety guidelines. Nevertheless, the use of the machine may still represent a risk of injury or death to the user or third parties, or damage to the machine and other material.

1.2.2 The machine may only be used when it is in correct working order and for its intended purpose. The operator must follow the instructions in the operating manual and be fully aware of the safety requirements and hazards posed by the machine! In particular, any faults that may compromise the safety of the machine must be repaired immediately.

1.2.3 The flat saw is intended solely for cutting joints in concrete or asphalt. Cutting of wood, plastic or metal (except reinforcements in concrete) is prohibited!
Any additional or other use is considered improper. The manufacturer/supplier is not liable for damages resulting from improper use.

Compliance with the operating manual and observation of inspection and service requirements are essential components of proper use.

1.3 Organisational measures

1.3.1 Always keep the operating manual readily available at the location where the machine is used!

1.3.2 In addition to the operating manual, observe and instruct the user in all generally applicable legal and other mandatory regulations on accident prevention and environmental protection!

1.3.3 Personnel assigned to work with the machine must have read the operating instructions and, in particular, the chapter on safety before beginning work. Reading the manual for the first time when already working on the machine is too late. This applies especially to persons who work on the machine only occasionally, such as those performing set-up and maintenance.

1.3.4 Check at least from time to time whether personnel are performing the work in compliance with the operating manual and paying attention to risks and safety factors!

1.3.5 Use personal protective equipment where necessary or if required by regulations.

- 1.3.6 Obey all safety and danger notices on the machine!
- 1.3.7 Ensure that all safety and danger notices on the machine remain clearly legible!
- 1.3.8 In the event of safety-relevant changes to the machine or its operating performance, stop the machine immediately and report the malfunction to the responsible authority/ person!
- 1.3.9 Do not make any modifications to the machine, add attachments, or reconfigure it without the supplier's permission!
- 1.3.10 Only use manufacturer's original parts!
- 1.3.11 Observe the stipulated periods or the periods given in the operating manual for inspections!
- 1.3.12 Equipment and tools appropriate to the work are absolutely essential for performing maintenance work.

1.4 Personnel selection and qualification:

- 1.4.1 Only reliable personnel may work with the machine.
Observe the minimum legal age.
- 1.4.2 Use only trained or instructed staff. Clearly establish individual responsibilities for operation, set-up, maintenance and repair!
- 1.4.3 Ensure that only assigned personnel work with the machine!
- 1.4.4 Specify machine operator responsibilities - including those pertaining to road traffic regulations - and authorise the operator to ignore any instructions from third parties that may compromise safety!
- 1.4.5 Personnel who are being trained or instructed on the machine or are in a general training program may only be permitted to work on the machine while under the constant supervision of an experienced person!
- 1.4.6 Work on electrical equipment on the machine may only be carried out by an electrician or by instructed persons under the guidance and supervision of an electrician in accordance with electrical regulations.

1.5 Safety instructions during specific operating phases

1.5.1 Normal operation

- 1.5.1.1 Avoid all working methods which may compromise safety!
- 1.5.1.2 Take steps to ensure that the machine is operated only in a safe and proper condition!
- 1.5.1.3 Check the machine for visible external damage and defects at least once per shift! Immediately report any changes (including in operational performance) to the responsible department/individual! If necessary, stop the machine immediately and secure it.
- 1.5.1.4 In the case of a fault, stop the machine immediately and make it secure. Immediately repair any faults!
- 1.5.1.5 Before starting work, become familiar with the work environment at the location where the machine is used. This includes obstacles in the work and traffic area, the load-bearing capacity of the surface, required securing of the construction site from the public traffic area and possibilities for help in case of accidents.

1.5.2 Special work in conjunction with use of the machine and maintenance and repairs during operation; disposal

- 1.5.2.1 Observe all the setting, maintenance and inspection activities and timetables, including instructions for replacing parts/secondary devices, as described in the operating manual! Only technically qualified personnel should carry out these activities.
- 1.5.2.2 Brief operating personnel before beginning special operations and maintenance work! Appoint supervisory personnel.
- 1.5.2.3 If the machine is completely shut down during maintenance and repair work, it must be mechanically secured to prevent accidental activation.
- 1.5.2.4 Before cleaning the machine with water or steam jet (high-pressure cleaner) or other cleaning agents, cover/seal all openings that, for reasons of safety and/or functioning, water/steam/cleaning agents must not be allowed to enter. Particularly endangered are electrical motors and switches.
- 1.5.2.5 After cleaning, the covers and tapes must be removed completely!
- 1.5.2.6 Always tighten loose screw connections during servicing and maintenance work!
- 1.5.2.7 Any safety devices removed during set-up, maintenance or repair must be reinstalled and checked immediately upon completion of the maintenance and repair work!
- 1.5.2.8 Dispose of fuel and consumable materials and replacement parts in a safe and environmentally-friendly manner!

1.6 Notes on specific hazard types

1.6.1 Electricity

- 1.6.1.1 Only use original fuses with the specified amperage! In the electrical power supply is interrupted, shut down the machine immediately!
- 1.6.1.2 Work on electrical equipment may only be carried out by electricians or by trained persons under the guidance and supervision of an electrician in accordance with electrical regulations.
- 1.6.1.3 The electrical equipment on the machine should be inspected/checked on a regular basis. Defects, such as loose connections or scorched cables, must be repaired immediately.

1.6.2 Dust

- 1.6.2.1 Observe applicable national regulations when working in enclosed spaces!

1.6.3 Noise

- 1.6.3.1 Wear required personal hearing protection!

1.7 Transport

- 1.7.1 When loading, use only hoists and lifting gear with sufficient capacity!
- 1.7.2 Appoint a trained supervisor for the lifting procedure!
- 1.7.3 Machines should be lifted with lifting gear correctly in accordance with the specifications in the operating manual (lifting points for load-lifting equipment, etc.)!
- 1.7.4 Use only suitable transport vehicles with sufficient lifting capacities!
- 1.7.5 Secure the load reliably. Use suitable lifting points!
- 1.7.6 Disconnect all power sources before moving the machine, even for very short distances! Ensure that the machine is correctly reconnected to the power supply before restarting!
- 1.7.7 Restart the machine strictly in accordance with the operating manual!

2. Machine description

2.1 Overview of components

Item 1	Cutting depth adjustment
Item 2	Catch for cutting depth adjustment
Item 3	Steering rod
Item 4	Saw hood fastener
Item 5	Saw hood
Item 6	Main switch
Item 7	Star-delta switch
Item 8	Motor fastener
Item 9	Motor fastener
Item 10	Water connection
Item 11	Connecting plug
Item 12	Machine frame
Item 13	Guide bar
Item 14	Scale for cutting depth adjustment
Item 15	Motor connection plug

2.2 Protective equipment

Item 5	Saw blade protective hood
Item 19	Kick-off switch

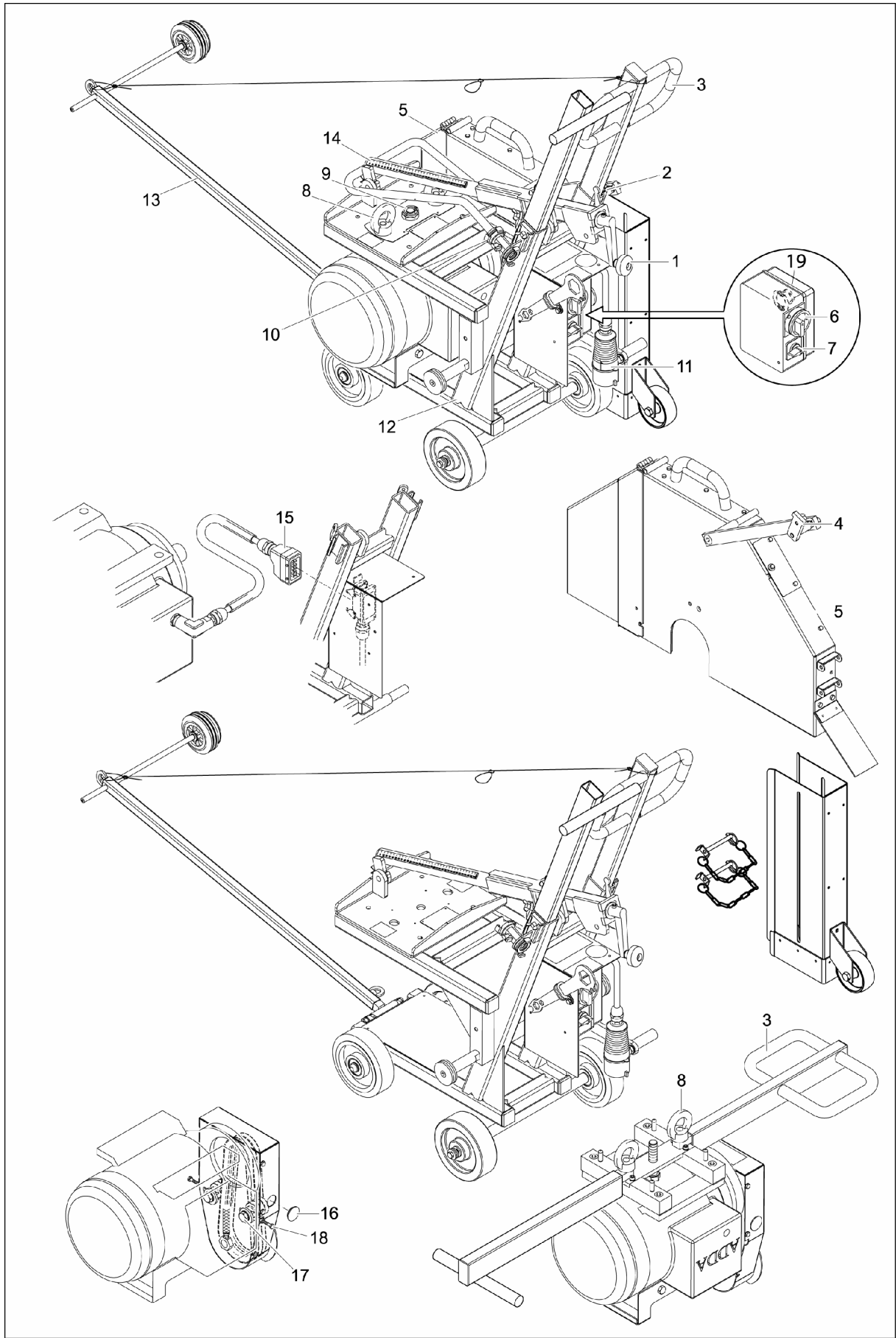

2.3. Technical data

	HFS811
Cutting depth	320 mm
Max. saw blade diameter	800 mm
Saw blade receptacle	25.4 mm
Dimensions L/W/H	1100/600/980 mm
Weight	158 kg
Left / right cut	Yes
Motor power	7.5 kW
Voltage / frequency	400 V / 50 Hz
Power consumption	16.1 A
Saw blade speed	1350 RPM

2.4. Noise characteristics HFS811

Workplace-related continuous sound pressure level for cutting concrete and asphalt (cutting depth 160 mm)

$$= 80 \text{ dB(A)}$$

with diamond segment saw blade NBA and NAK

Sound power level with the same saw blades and conditions

$$= 96 \text{ dB(A)}$$

The workplace-related continuous sound level corresponds to the assessment level in an eight-hour exposition.

ATTENTION! Hearing protection must be worn when 90 dB(A) is exceeded!

2.5 Handle vibration

Operating condition	Measured vibration severity k in direction		
	x	y	z
Cutting of asphalt blade diameter 600 mm cutting depth = 220 mm	2.5 ms ⁻²	2.4 ms ⁻²	2.6 ms ⁻²

In taking the measurements, the following standards were considered:
ISO 5349, DIN ENV 25349, DIN 45671, VDI 2057

3. Placement in operation

Before you start the flat saw, you must become familiar with its operation.

3.1 Preparations for start

- If required, install saw blade (see 5.2 and 5.3)
- Move the flat saw into position

3.2 Test direction of rotation of the saw blade

- Switch on main switch (item 6)
- Switch star-delta switch (item 7) briefly to "star"
- Check the direction of rotation of the saw blade
 - ❖ Observe rotation-direction arrow on the hood

3.3 Change in direction of rotation

- Switch off main switch (item 6)
- Remove supply line cable from the plug (item 11)
- Turn the phases of the plug (item 11) with a screwdriver
 - ❖ Push white disc inward and turn

3.4 Test run

- Turn main switch (item 6)
- Set the switch (item 7) to "star"
- Wait until the motor has reached a uniform speed (uniform sound)
- Set the switch (item 7) further to "delta"

ATTENTION! Is the saw blade adequately supplied with cooling water?

- ❖ Guide bar disk and saw blade are over the cut line
- Attach water hose to the coupling (item 10) and open the valve
- Slowly initiate downward movement with crank (item 1) - until the saw blade begins to cut
- Set cutting depth indicator (item 14) to "zero"
- Dip saw blade down to the desired cutting depth (indicator item 14)
 - ❖ Turn crank (item 1)
- Slowly start feed movement

Caution! - Dry cutting is not permitted

- Inadequate cooling water results in early wear or malfunctioning of the saw blade

4. Transport

4.1 Transport position means:

- Guide bar is folded up
- Move saw arm upward until the saw blade has adequate ground clearance
- Lock spindle with locking bar (item 2)

4.2 Movement with the crane

- Observe all points of 4.1
- Attach the crane suspension gear to the rings (item 8)
 - * Pay attention to machine weight
- Lift and set down carefully

4.3 Disassemble flat saw into 3 parts

- Loosen wing screw (item 4)
- Remove the saw hood (item 5) with rods
- Open plug (item 15)
- Disconnect water hose
- With the crank handle (item 1), turn the motor completely downwards
- Remove the eyebolts (item 8)
- Pull out steering rods (item 3)
- Remove split pin and hexagon nut (item 9)
- With the crank handle (item 1), turn the motor receptacle upwards.
- Fasten both steering rods (item 3) to the motor with the eyebolts (item 8)
- The motor can now be transported by two people
- Assemble in the reverse sequence

5. Operation

5.1 Normal cutting operation

Attention: The machine may only be operated on electrical circuits protected with ground fault circuit interrupters.

- Adjust feed speed to the cutting depth and the material being worked on
CAUTION! If feed force is too large, the flat saw attempts to "climb" forward
- Ensure there is adequate water on the saw blade (observe point 7, Maintenance)
 - * Use only fresh or clean water

5.2 Saw blade replacement

- Raise the saw blade somewhat
 - Turn the flat saw completely off
 - Unplug feed line
 - Loosen the wing screw (item 4)
 - Pull the saw hood holder out of the C-rail
 - Lift the saw hood upward
 - Open the flange nut (right-hand thread)
 - Remove saw flange thrust washer and saw blade
 - Thoroughly clean the flange's contact surfaces, if necessary
 - Install new saw blade
- ATTENTION!** * **Rotation direction arrow on the saw blade must match the one on the hood**
- * **The driving pin on the flange must seat in the driving hole on the saw blade**
- Install the saw flange thrust washer and the flange nut
- ATTENTION!** * **Install the retaining split pin**
- Install the saw hood

5.3 Change from right to left cut

- Loosen wing screw (item 4)
- Remove the saw hood (item 5) with rods
- Open plug (item 15)
- Uncouple the water hose
- With the crank handle (item 1), turn the motor completely downwards
- Remove the eyebolts (item 8)
- With the crank handle (item 1), turn the motor receptacle ca. 8-10 cm upwards
- You can now swivel the motor 180°
- Turn the motor receptacle downward again (item 1)

ATTENTION! Fit screws and pins

- Install eyebolts (item 8)
- Install the water hose fastener (item 10) on the other side

Attention! Turn saw blade (see also 5.2)

- Close plug (item 15)
- Install saw hood (item 5) (move rods)
- Change saw blade rotation direction by changing the poles of the plug (item 11) (see also 3.3)

6. Shut-down

- Turn back switch (item 7)
- Set main switch (item 6) to "zero"
- Remove supply line
- Crank saw hood up until the brake presses against the wheel

7. Maintenance

	Daily	Weekly	Monthly	Semi-annually
Check V-belt (see 8.2)	X			
Check screws (item 8) (tightened?)	X			
Lubricate the spindle of the cutting depth adjustment (item 1) with spray lubricant			X	

All screws must be tightened after ca. 20 hours of operation! V-belts must be tightened after ca. 2 hours of operation!

8. Repair of malfunctions

8.1

Malfunctions	Possible cause	Remedies
Too little cutting performance; saw blade stops	V-belt slips	Tighten, replace (see 8.3)
No water on the saw blade	Water supply strainer clogged strainer dirty	Clean water line strainer; flush water supply with pressure (5-8 bar)

8.2 Check the V-belt tension

- Remove protective cap (item 16)
- With medium force, it should be possible to depress the V-belt by one belt width

8.3 Adjusting the V-belt tension (item 16)

- Open the hexagon nut (item 17)
- Turn the screw (item 18) as needed
- Tighten the hexagon nut (item 17)
- The V-belt can be tightened again on the opposite side.

8.4 Adjustment of the protective motor switch

The protective motor switch in the switch box is to protect the kick-off switch and to trigger the thermo sensing device. The thermo sensing device has to be adjusted at 14 A. The motor is directly protected through the thermo sensing device.

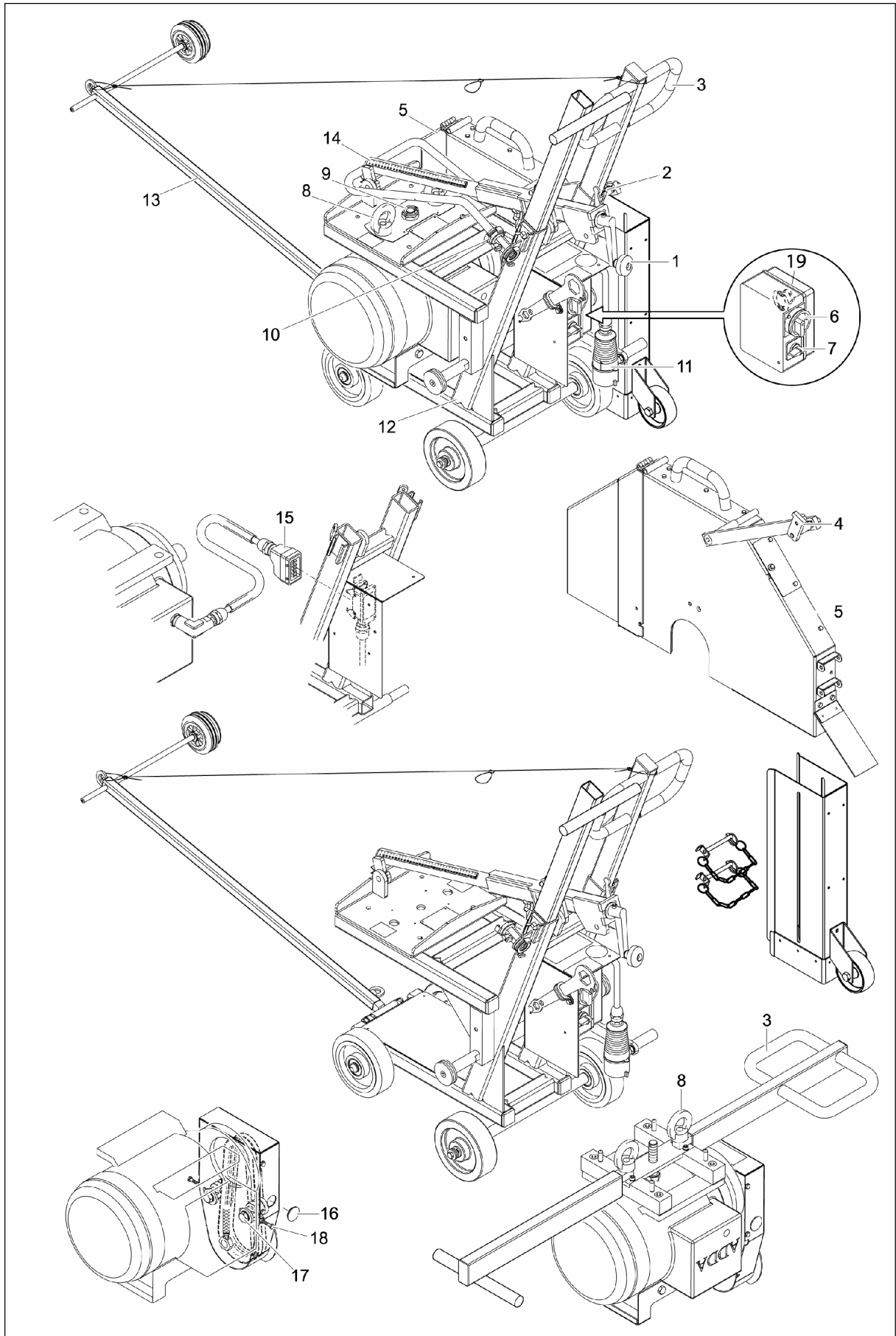

10. Warranty

The warranty period for this machine is 12 months. The following wearing parts are covered under warranty only if the wear is not caused by operation.

Wearing parts are parts that are subjected to operating wear when the machine is used as intended. The wear time cannot be defined uniformly; it differs according to the intensity of use. Wearing parts must be serviced, adjusted, and, if necessary, replaced specifically by machine according to the manufacturer's operating manual.

Operation-related wear does not justify malfunction claims.

- Feed and drive elements such as racks, gears, pinions, spindles, spindle nuts, spindle bearings, ropes, chains, sprockets, belts
- Seals, cables, hoses, collars, plugs, couplings, and switches for pneumatic, hydraulic, water, electrical, and fuel systems
- Guide elements such as guide strips, guide bushes, guide bars, rollers, bearings, non-skid covers
- Clamping elements of quick-disconnect systems
- Flushing head seals
- Sliding and roller bearings not running in an oil bath
- Shaft seal rings and sealing elements
- Friction and overload couplings, brake gear
- Carbon brushes, collectors
- Easy-disconnect rings
- Control potentiometers and manual switching elements
- Fuses and lamps
- Fuel and consumables
- Fastening elements, such as plugs, anchors, and screws
- Bowden wires
- Lamellae
- Diaphragms
- Spark plugs, glow plugs
- Parts of the reversing starter, such as starting rope, catch, roller, spring
- Sealing brushes, sealing rubber, splash guard flaps
- Filters of all kinds
- Drive and deflection rollers and bands
- Rope lay protection elements
- Running and drive gears
- Water pumps
- Cutting material transport rollers
- Drilling, separating, and cutting tools
- Conveyor belt
- Rubber wipers
- Needle felt protection
- Energy storage

EEC Declaration of conformity for

Flat Saw HFS811

Producer	TYROLIT Hydrostress AG Witzbergstrasse 18 CH-8830 Pfäffikon
Description of machine	Flat saw with 320 mm cutting depth and with 7.5 kW electric motor and frequency changer
Relevant EC-Directives	EC Machine Directive (Council Directive 98/37/EEC, EC Low Voltage Directive (LVD) (Council Directive 73/23 EEC), EC Electromagnetic Compatibility Directive (EMC) (Council Directives 89/336/EEC), EN 292 part 1 and 2, EN 500 part 1 and part 5, EN 294, EN 349, EN 50081-1, EN 50065-1, EN 55014, EN 50082-1, EN 55104, EN 60204, Noise Directives 2000/14/EEC
Authorized person legally responsible:	

.....
Roland Kägi
Manager Development & Production

