

MODULAR HYDRAULIC DRILLING GEARBOX **DGB1000★★★**

Core drilling up to Ø 1000 mm

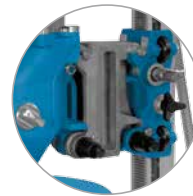

Optimised drill bit attachment for large bore drilling



ModulDrill quick change clamping system for quick, easy and safe attachment



Bores with a diameter of up to 1000 mm with ModulDrill distance plates

In accordance with the TYROLIT modularity principle, the DGB1000*** delivers optimum rotational speeds and impressive performance in

conjunction with either the electric high-frequency motor or hydraulic standard motor options, by means of 8 transmission stages – two speeds

at the drilling gear box and up to four stages via the relevant drive. With optimised drill bit attachment for large diameters and high torques.

Technical data

Modular drilling gearbox

Output	20 kW / 25 kW
Drill diameter range with DRA500***	150 - 500 mm
Drill diameter range with BC-2	150 - 1000 mm

Design

2-stage gearbox
Special large hole flange
ModulDrill quick change clamping system

Dimensions & weight

Length	338 mm
Width	213 mm
Height	226 mm
Weight	15,7 kg

System recommendation

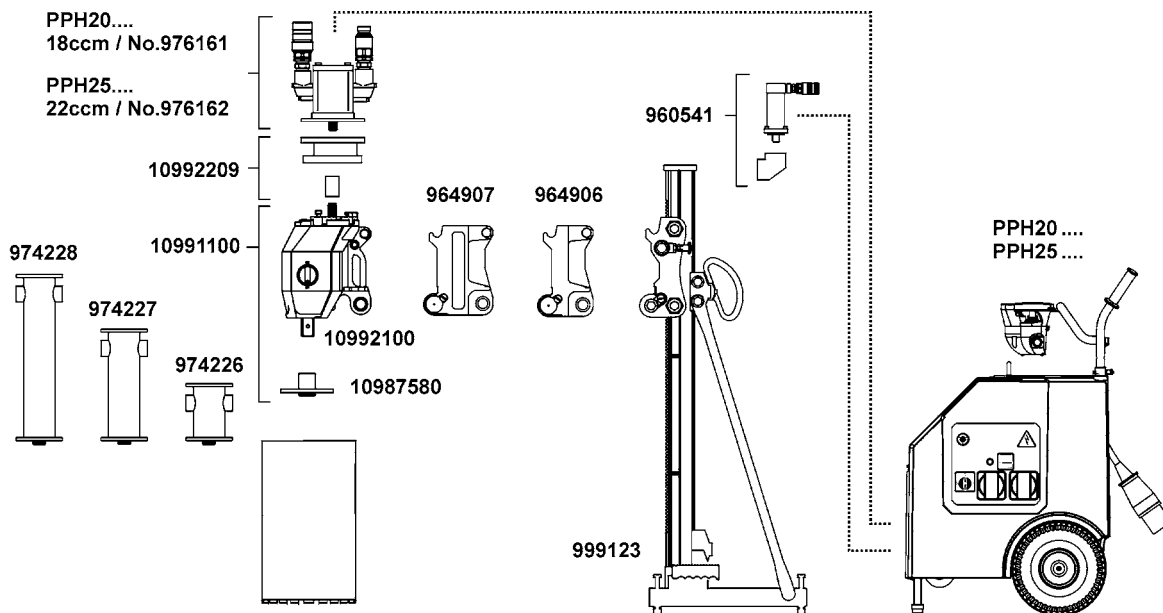

Core drilling system hydraulic from Ø 150 mm to Ø 500 mm

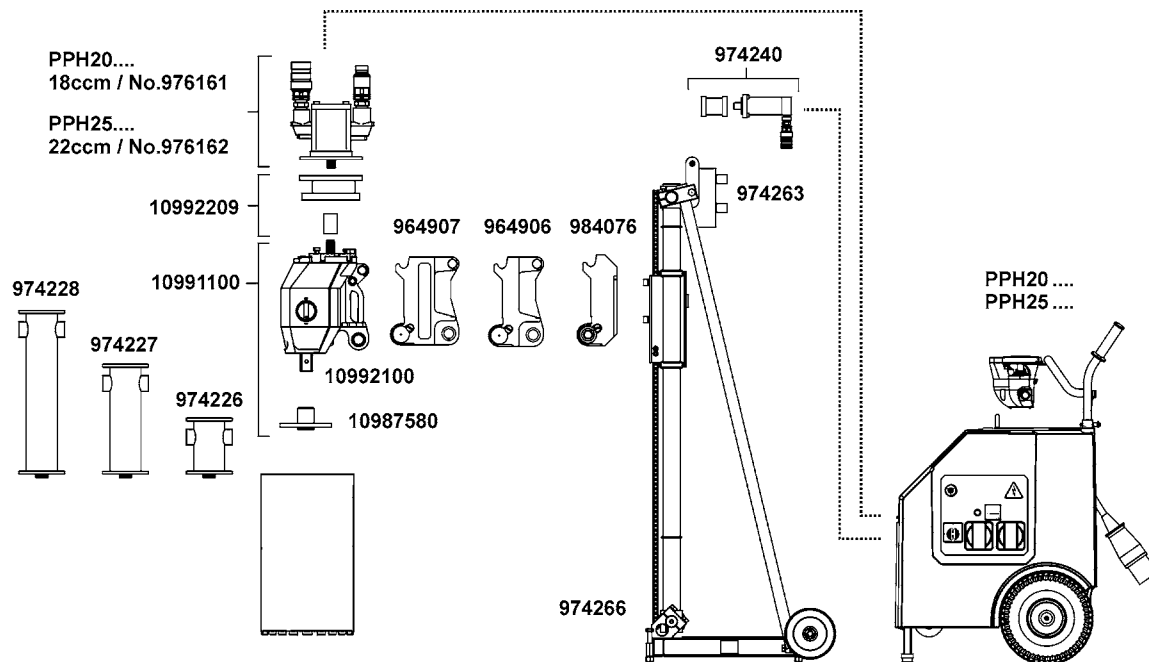

Core drilling system hydraulic from Ø 150 mm to Ø 1000 mm